



IDLERS

SPECIALLY DESIGNED
FOR FERTILIZER INDUSTRIES



About ULMA Conveyor Components

ULMA Conveyor Components designs, manufactures and supplies rollers, idler frames, and garlands for the bulk handling industry, through out the world.

- +40 years of experience in North African phosphate mines, in continuous development of the product.
- In large Middle Eastern sulphur applications, ULMA rollers were found to produce the best results.

Special design

ULMA Rollers are specially designed for fertilizer industry:

- Potash
- Phosphate , DAP, MAP, NPK
- Urea
- Sulphur
- Agricultural salt

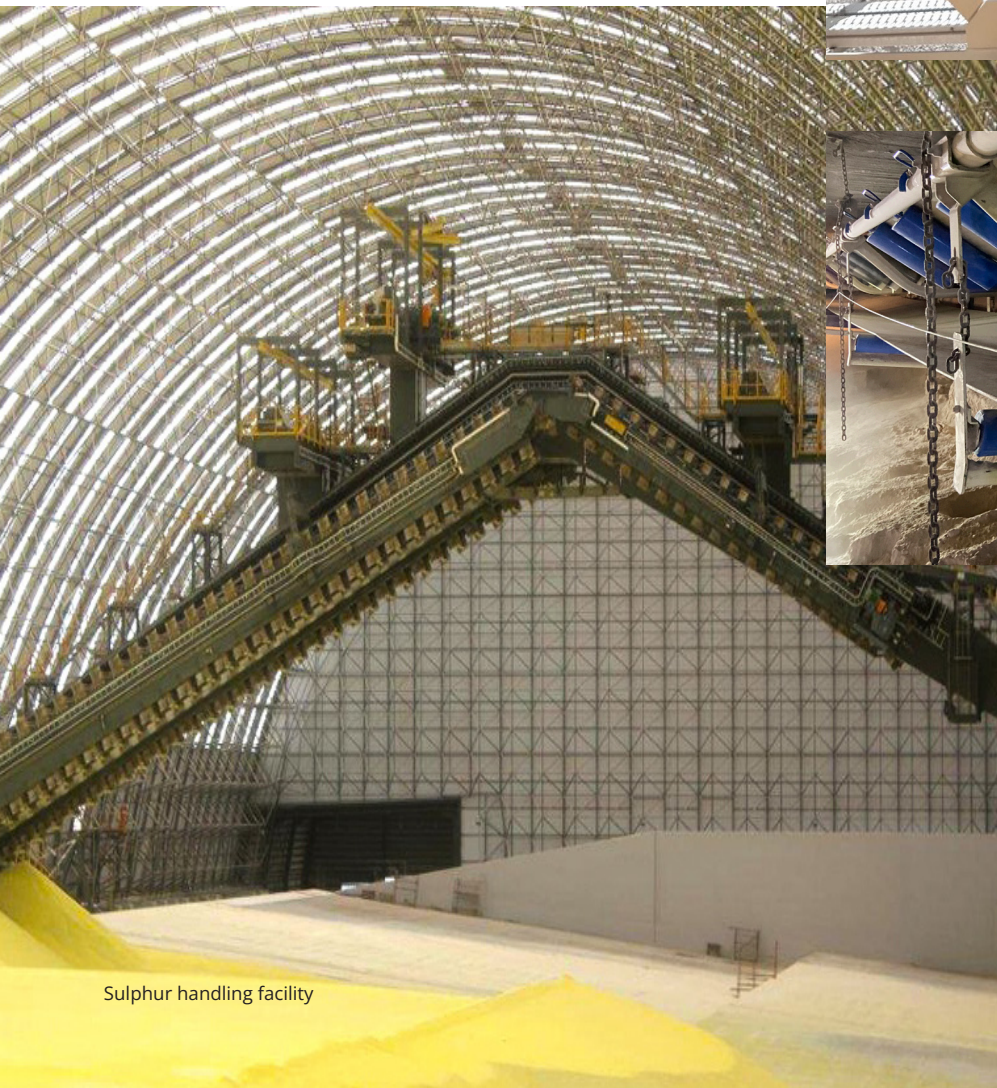

Sulphur handling facility



Potash underground mine

Designed for underground applications and conditions



II 2GD c
I M2 c

Explosive areas

The patented specially designed sealing system ensures long life of the roller and protects the bearings against dust, corrosion, and humidity.

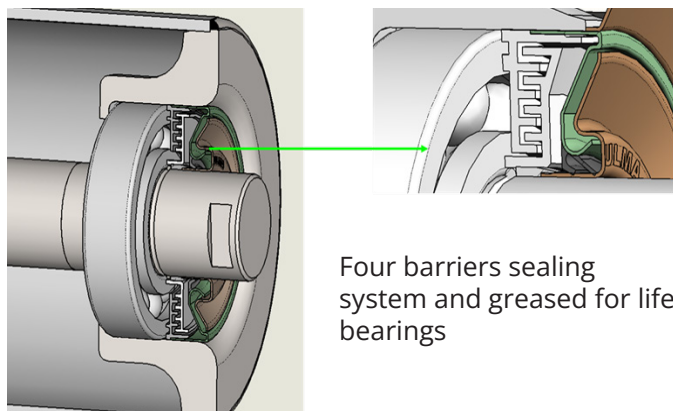

Four barriers sealing system and greased for life bearings

It prevents premature bearing seizure due to dust and humidity, and has very low power consumption:

Approved and passed the following tests:

- DIN 22112-3 Waterproof test
- DIN 22112-3 Dustproof test
- 45° position Dustproof test (required in North African phosphate mines to be validated)
- DIN 22112-3 Running Resistance test

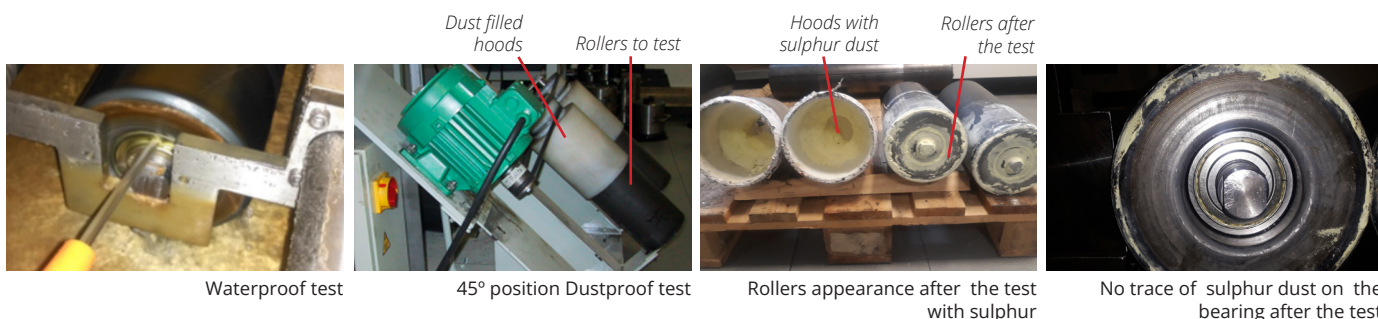

Waterproof test

45° position Dustproof test

Rollers appearance after the test with sulphur

No trace of sulphur dust on the bearing after the test

All parts are produced in state of the art manufacturing plant and with the latest technology to ensure the bearings are perfectly aligned.

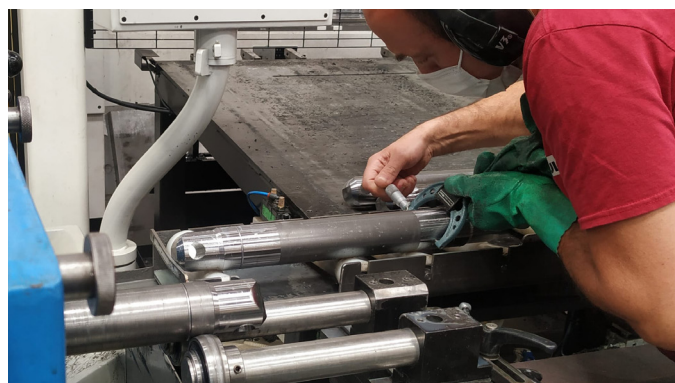
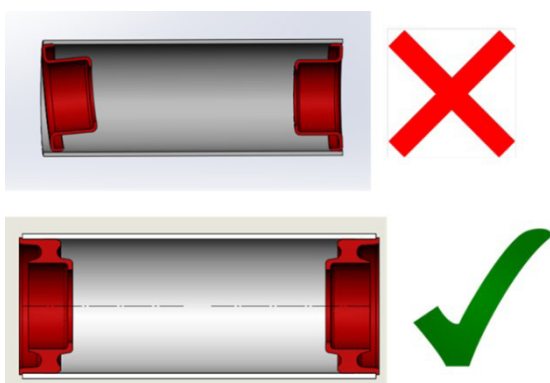

Engineered and customized solutions for the most abrasive and sticky materials.



Polyurethane rings



HDPE coating

ULMA CONVEYOR COMPONENTS

in the world



THE AMERICAS

- **CANADA**
Mr Rajesh Shah
- **CHILE**
Antofagasta - Santiago
- **MEXICO**
Ms Nidia Santos
- **PERU**
Arequipa - Lima
- **USA**
Mr Rajesh Shah
- **CENTRAL AMERICA**
Mr Edwin Acevedo

EUROPE/AFRICA

- **SPAIN**
Otxandio - Bizkaia
- **DENMARK**
Scandi Roll
- **FINLAND**
New Paakkola
- **GERMANY**
Rödermark
- **GREECE**
Solergon
- **FRANCE**
Ms Isabelle Van Caillie
- **MOROCCO**
Eximcom
- **NORWAY**
Aanestad Service AS.
- **PORTUGAL**
OZEC Equipamentos Industriais Lda.
- **SLOVENIA, CROATIA, BOSNIA, HERZEGOVINA, SERBIA AND KOSOVO**
Siming d.o.o

ASIA/AUSTRALIA

- **AUSTRALIA**
Ms Isabel Zapiain
- **INDONESIA**
Mr Herman Gunawan
- **THAILAND AND LAOS**
Giant Tire and Service Co.Lt.
- **UNITED ARAB EMIRATES**
Arab Emirates Bandac
- **MIDDLE EAST**
KENZ Jordan for Industrial Supplies

■ ULMA CONVEYOR COMPONENTS
■ COMMERCIAL DELEGATIONS



www.ulmaconveyor.com

